

# RIV509 Hydropneumatic tool for blind bolts

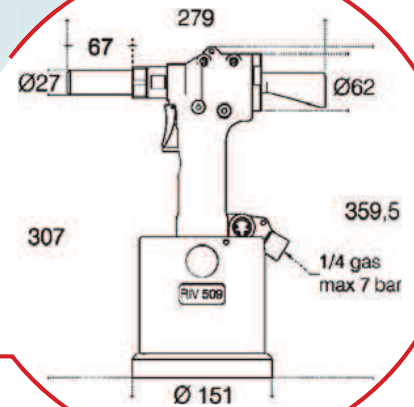

**Code 3243500**

To place RIVLOCK and RIVLOCKGRIP blind bolts Ø 6.4, 8.0 and 10.0.

The innovative technical devices adopted allowed a reduction in weight and dimension, giving a very good solution to all the limits generated by the volume of the control unit, which has been eliminated.

Moreover the tool is very practical, handy and perfect to be used almost anywhere. RIV509 operates with both a very strong pull force and a very strong reverse force (hydropneumatic piston); the second one is necessary to make the ejection of the collar possible.

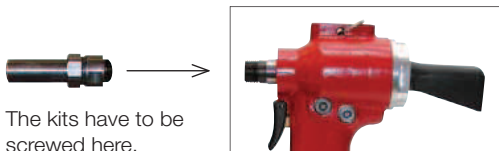

The kits have to be screwed here.

## Kits for RIVLOCK-RIVLOCKGRIP

| Picture | Kit (complete head) | Ø    | Code    |
|---------|---------------------|------|---------|
|         | 509/64B             | 6.4  | 3270000 |
|         | 509/80B             | 8.0  | 3344400 |
|         | 509/100B            | 10.0 | 3293000 |
|         | 509/64G             | 6.4  | 3656700 |
|         | 509/80G             | 8.0  | 3649000 |
|         | 509/100G            | 10.0 | 3649100 |

## Kits for BOM®

| Picture | Kit (complete head) | Ø   | Code    |
|---------|---------------------|-----|---------|
|         | 509/50M             | 5.0 | 3359000 |
|         | 509/64M             | 6.4 | 3359400 |
|         | 509/80M             | 8.0 | 3349800 |

## Kits for MAGNARIV

| Picture | Kit (complete head) | Ø   | Code    |
|---------|---------------------|-----|---------|
|         | 509/98              | 9.8 | 4201700 |

RIV509 is supplied in a case without the frontal head kit. Choose the correct one, according to the fastener to be placed, and order it separately (see kits for RIVLOCK/RIVLOCKGRIP/BOM®/MAGNARIV).

## Technical data and features

|                                   |                                 |
|-----------------------------------|---------------------------------|
| Air working pressure              | <b>6 bar</b>                    |
| Min-max air pressure              | <b>5/7 bar</b>                  |
| Air consumption per cycle (6 bar) | <b>14 lt</b>                    |
| Stroke                            | <b>19 mm</b>                    |
| Max power (6 bar)                 | <b>35000 N</b>                  |
| Weight (without kit)              | <b>4.200 Kg</b>                 |
| Vibrations                        | <b>&lt; 2,5 m/s<sup>2</sup></b> |
| Noise level                       | <b>&lt; 80 dB (A)</b>           |

## Optional



| Collar cutter heads | Ø    | Code    |
|---------------------|------|---------|
| KIT509/50C          | 4.8  | 4043500 |
| KIT509/64C          | 6.4  | 4043900 |
| KIT509/80C          | 8.0  | 4044000 |
| KIT509/100C         | 10.0 | 4044100 |

Collar cutter heads for standard collar (not flanged).

