

RIV506 Hydropneumatic tool for structural blind rivets

new

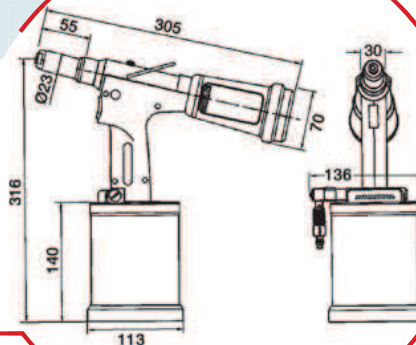
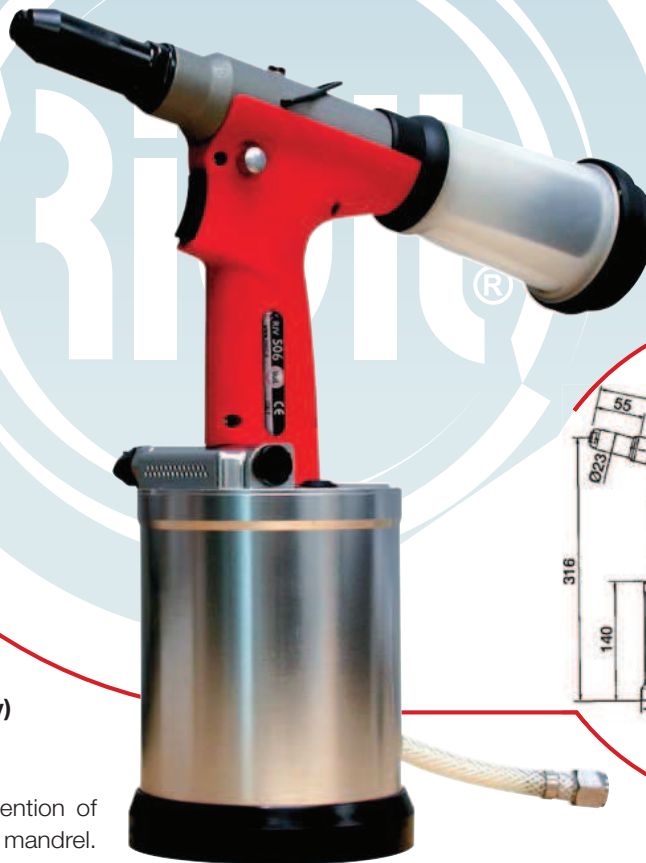

Code 4692100

To place structural blind rivets, in all materials, Ø 6.4 (Magnariv, Monriv) and Gtrriv Ø 7.7.

RIV506 is a hydropneumatic tool with retention of the blind rivet and capture of the separated mandrel. Plastic handle and aluminium body make the tool light and handy, and consequently easy to use for operators. RIV506 combines functionality with a highly competitive price, which makes it very attractive for those who uses this kind of tool continuously and professionally.

Fittings

Description	Pc	Code
Nosepiece Ø 4.8 mm	1	4169100
Nosepiece Ø 6.4 mm for structural rivets (on head)	1	4724400
Nosepiece Ø 4.8-3/16 mm for Monriv rivet	1	2524800
Nosepiece Ø 6.4-1/4 mm for Monriv rivet	1	4041900
Nosepiece Ø 6.4 mm for Lockriv rivet	1	4173500
Nosepiece Ø 6.4 mm for standard rivets	1	4041700
Nosepiece Ø 6.4 mm for Magnariv rivet	1	4041800
Jaws (3 pcs)	2	4723300
Jaw opener	1	4133900
Jaw return spring	1	4134000
Jaws carrier cone	1	4133800
Oil syringe	1	-
Oil	1	-
Hexagonal allen wrench 3 mm	1	-
10-12 mm wrench	1	-
16-17 mm wrench	2	-

The tool is supplied with kit Ø 6.4 for structural blind rivets already assembled.

Technical data and features

Air working pressure	6 bar
Min-max air pressure	5/7 bar
Air consumption per cycle (6 bar)	4.8 lt
Stroke	20 mm
Max power (6 bar)	18000 N
Weight	1.866 Kg
Vibrations	< 2,5 m/s²
Noise level	78.5 dB (A)

Optional

Picture	Description	Code
	Kit 506 - extension 100 mm	4204300
	Kit 506 - extension 200 mm	4226800

